



This 4-axle intermodal wagon is suitable for both **containers and swap bodies**.

The wagon complies with the latest European legislations in force, i.e., TSI WAG, EN, UIC and has the TEN GE marking for traffic operation.

Ce wagon intermodal à 4 essieux convient aussi bien aux **conteneurs** qu'aux **caisses mobiles**.



Le wagon répond aux dernières législations européennes en vigueur, à savoir les TSI WAG, EN, UIC et possède le marquage TEN GE pour l'exploitation.

Dieser 4-achsige intermodale Güterwagen ist sowohl für **Container** als auch für **Wechselbehälter geeignet**.

Der Wagen entspricht allen europäischen Vorschriften und Gesetzgebungen: TSI WAG, EN, UIC und TEN GE.

## Sgmmnss 40'



CONTAINER-CARRIER – PORTE-CONTENEURS – CONTAINER FLACHWAGEN

 General specifications	 Caractéristiques générales	 Allgemeine Spezifikationen	
Gross weight	Poids total sur rail	zul. Gesamtgewicht	90 t
Payload	Charge utile	Nutzlast	73.8 t
Length over buffers	Longueur hors tout	Länge über Puffer	13.54 m
Tare weight	Tare	Eigengewicht	16.2 t (± 2%)
Max. Speed	Vitesse maximale	Max. Geschwindigkeit	120 Km/h
Loading plan	Plan de chargement	Ladeschema	i.e. annexe siehe Anhang
Loading height	Hauteur de chargement	Ladehöhe	1155 mm
Draw hook	Crochet de traction	Zughaken	150 t
Minimum curve radius for single wagon (loaded)	Rayon de courbure minimal pour un wagon isolé (chargé)	Minimaler Kurvenradius für Einzelwagen (beladen)	35 m
Minimum curve radius for coupled wagons in train	Rayon de courbe minimum pour les wagons couplés dans le train	Minimaler Kurvenradius für gekuppelte Wagen im Zug	150 m

### Transported products - Produits transportés - Transportierbare Produkte

Containers, Swap bodies  
Conteneurs, Caisses Mobiles  
Container, Wechselbrücken



 Fittings	 Équipements	 Ausstattung	
Container spigot - hinged	Cheilles de fixation (à charnière)	Containerzapfen (klappbar)	8
Buffers	Tampons	Puffers	Cat. A
GPS Tag	Balise GPS	GPS Telematik	Yes/Oui/Ja

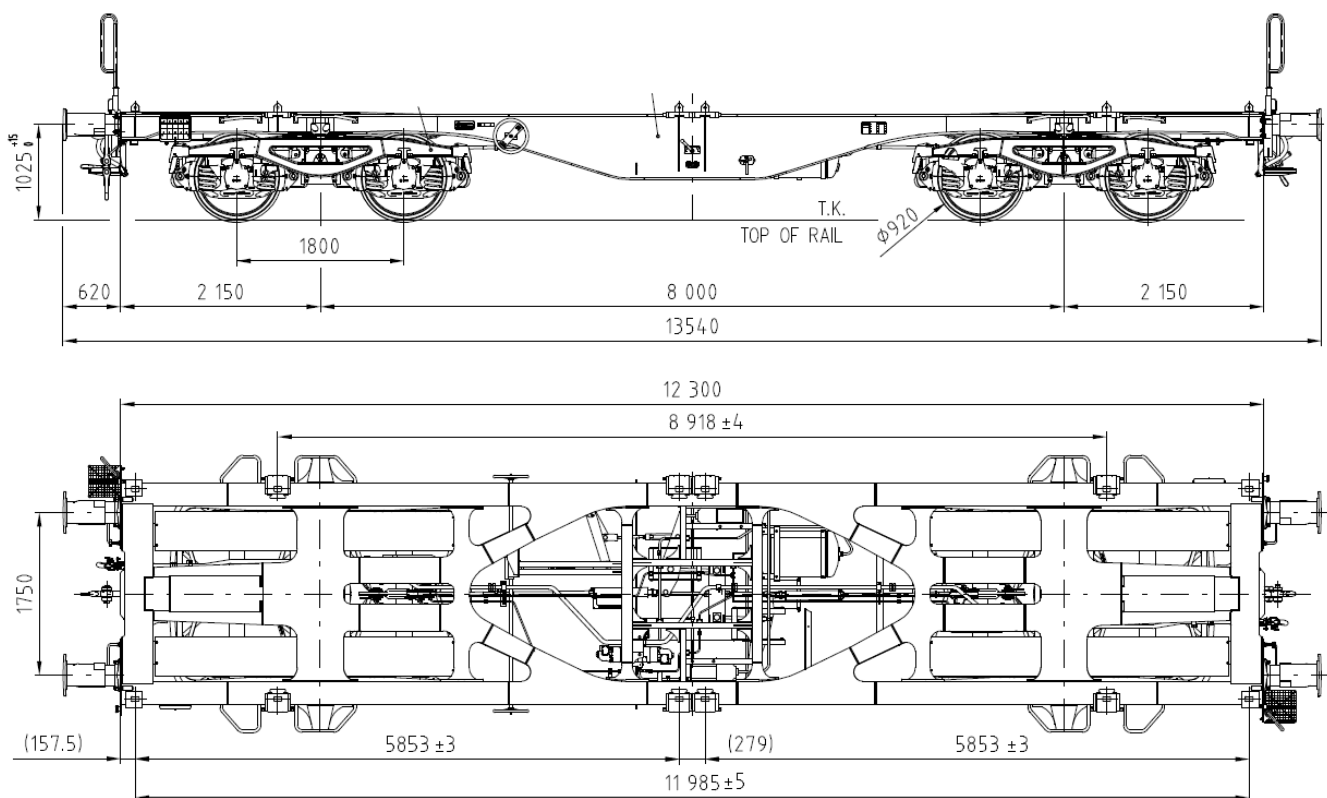

### Loading - Chargement - Lastgrenzraster

	A	B1	B2	C2	C3	C4	D2	D3	D4
<b>S</b>	47,8 t	51,3 t	55,8 t	65,8 t			70,4 t	73,8 t	
<b>SS</b>	47,8 t	51,3 t	55,8 t	63,8 t			63,8 t		

Loading plan

